

WONDERWALL®

PRODUCTS • LTD

Weather Proof Products



WATER & DUST
RESISTANT



Welcome to our information booklet

Our market leading and distinctive exterior showcases are certified to the IP55 requirements or EN60529 against water and dust ingress.

We offer 3 finishes, satin aluminium, powder coated aluminium in 5 colours and our unique wood effect aluminium which has been tried and tested over the years in our typically English weather. The light oak effect is produced by a special printing process, its not a foil wrap!

Each showcase has support stays and 2 matching locks to keep the contents secure. The interior has a choice of 18 loop nylon colours + cork. We currently offer 7 sizes, each one designed to take a specific number of A4 sheets. The PET glazing is 3mm thick.

Contents

Outdoor

Lockable Noticeboard	4
Post mounted noticeboard	5-6
External poster frames	7
Pavement signs	8





Here we show the 18 loop nylon colours + cork available for the interior of your showcase and also the 7 choices of case finish.

Below are the 7 sizes available and the relevant part numbers as used on our website.

FRAME COLOURS



Size H 570mm
W 712mm

Aluminium **WN15-WN135**
Coloured **WN17-WN259**
Wood **WN16-WN120**

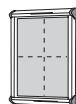

Size H 750mm
W 537mm

Aluminium **WN15-WN129**
Coloured **WN17-WN264**
Wood **WN16-WN121**

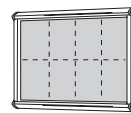

Size H 750mm
W 967mm

Aluminium **WN15-WN130**
Coloured **WN17-WN269**
Wood **WN16-WN122**

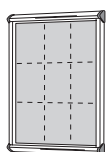

Size H 1050mm
W 752mm

Aluminium **WN15-WN131**
Coloured **WN17-WN274**
Wood **WN16-WN123**

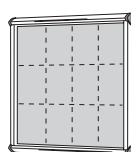

Size H 1050mm
W 1012mm

Aluminium **WN15-WN132**
Coloured **WN17-WN279**
Wood **WN16-WN124**

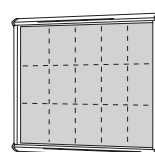

Size H 1050mm
W 1182mm

Aluminium **WN15-WN133**
Coloured **WN17-WN284**
Wood **WN16-WN125**

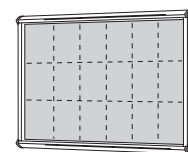

Size H 1050mm
W 1397mm

Aluminium **WN15-WN134**
Coloured **WN17-WN289**
Wood **WN16-WN126**



Post mounted Lockable Outdoor

The 4 larger sizes of our showcase are also available with mounting posts. Fixings supplied.

Our preferred posts are set into the ground with concrete giving 2 metres above ground and 500mm below.

We do also offer flange mounted posts but you must be absolutely sure the concrete surface used is suitable.

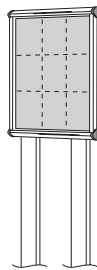

Size H 1050mm
W 752mm

Aluminium **WN18-WN293/01**
Coloured **WN18-WN294/01**
Wood **WN18-WN299/01**

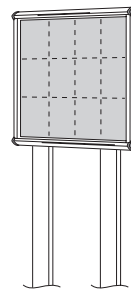

Size H 1050mm
W 1012mm

Aluminium **WN18-WN300/01**
Coloured **WN18-WN301/01**
Wood **WN18-WN306/01**

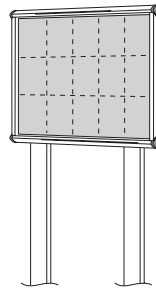

Size H 1050mm
W 1182mm

Aluminium **WN18-WN307/01**
Coloured **WN18-WN308/01**
Wood **WN18-WN313/01**

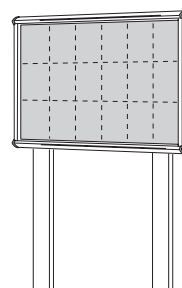

Size H 1050mm
W 1397mm

Aluminium **WN18-WN314/01**
Coloured **WN18-WN315/01**
Wood **WN18-WN320/01**



FRAME COLOURS



ALUMINIUM BLUE



RED GREEN



WHITE BLACK



WOOD

Additional Showcase for post mounted

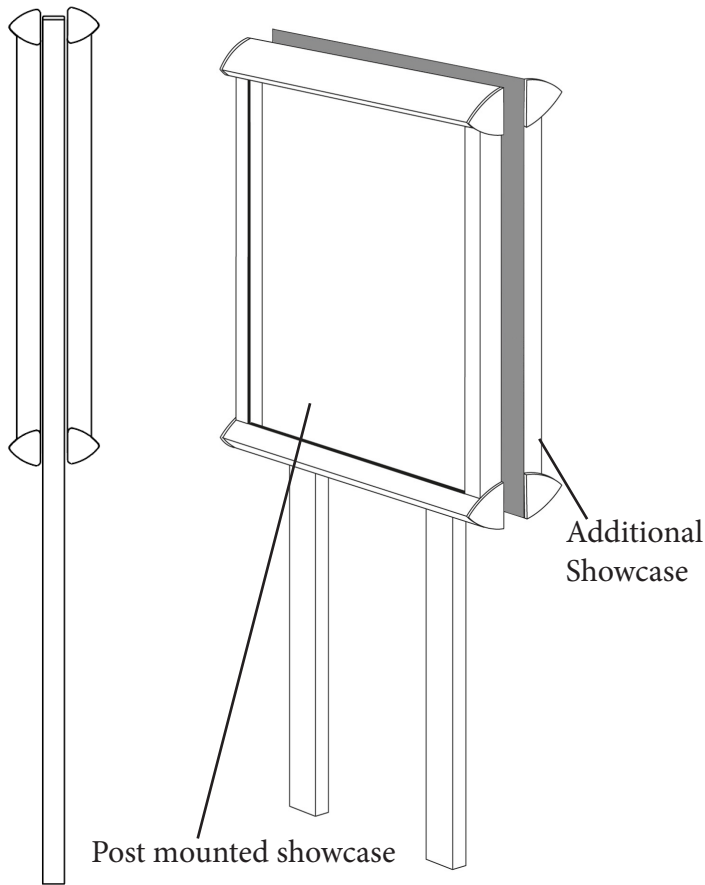

For the 4 post mounted sizes we can also supply an additional showcase which fits to the reverse side of the posts

All showcases are made to order in our factory so check delivery times but allow 10-14 days.

FRAME COLOURS

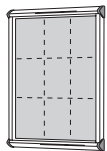

Size H 1050mm
W 752mm

Aluminium **WN18-WN494**
Coloured **WN18-WN502**
Wood **WN18-WN498**

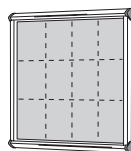

Size H 1050mm
W 1012mm

Aluminium **WN18-WN495**
Coloured **WN18-WN503**
Wood **WN18-WN499**

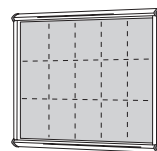

Size H 1050mm
W 1182mm

Aluminium **WN18-WN496**
Coloured **WN18-WN504**
Wood **WN18-WN500**

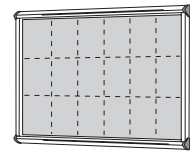

Size H 1050mm
W 1397mm

Aluminium **WN18-WN497**
Coloured **WN18-WN505**
Wood **WN18-WN501**

Security Poster Frame



Size A4 H 297mm
W 210mm

Frame **WP04-WP172**
Lockable **WP03-WP181**



Size A3 H 420mm
W 297mm

Frame **WP04-WP173**
Lockable **WP03-WP182**



Size A2 H 594mm
W 420mm

Frame **WP04-WP174**
Lockable **WP03-WP183**



Size A1 H 840mm
W 594mm

Frame **WP04-WP175**
Lockable **WP03-WP184**



Size A0 H 1189mm
W 840mm

Frame **WP04-WP176**
Lockable **WP03-WP185**



Size B1 H 1000mm
W 2700mm

Frame **WP04-WP178**
Lockable **WP03-WP186**



Size B2 H 700mm
W 500mm

Frame **WP04-WP179**
Lockable **WP03-WP187**

Lockable Poster Case



Available in 7 sizes, this locking poster case is the ideal way to display posters and notices outdoors under a canopy or porch. Notices are held in place via clips on the inside and the weather resistant frame protects from water and dust ingress. Locks on the frame ensure these poster cases are tamperproof and suitable for use within public areas.

Weatherproof Security Poster Frames are easy to use and keep contents dry and secure. Frames have a weatherproof seal to protect posters and notices from water and dust. A UV protective film prevents fading and stops dust and water getting in. A special tool is supplied for opening the frame. An affordable solution available in 7 different sizes up to A0 (1189 x 840mm) for external poster display.

Showpoint Water Base Pavement Sign

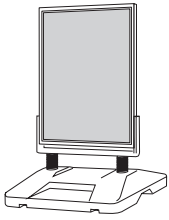

Size H 841mm
W 594mm
A1 **WP10-WP205**

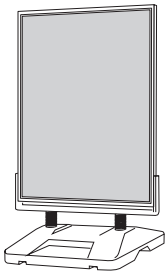

Size H 1189mm
W 841mm
A0 **WP10-WP206**



Our weatherproof double sided pavement sign has the additional benefit of being IP56 rated against water and dust ingress. The heavy duty snap frames have a special gasket which forms a tight seal against the UV poster covers; for maximum poster protection. Special multi-use adhesive tape prevents posters from slipping down. The base can be water filled for additional stability (approx 55L) and an optional tool adds a third wheel for easy movement. 2 Year Guarantee

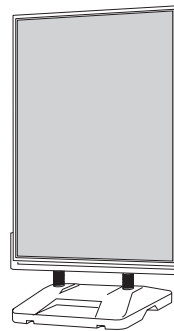

Size H 1524mm
W 1016mm
WPL310

This large double sided wind sign is designed to take posters (H) 1524 x (W) 1016mm. Fill the base with water for maximum stability. The rubber seal ensures this product is waterproof and the easy to open snap frames include anti-reflex covers. 2 wheels aid mobility and there is an optional carry tool sold separately.

Master Flex pavement signs

The contemporary design of this double sided A1 pavement sign will enhance any message or promotion of your choice. Made from HDPE (high density polyethylene) this product is completely weather resistant and the clever tamper resistant seal ensures your posters are protected from the elements. There is space for a logo should you require and there are 2 castors fitted for easy movement. No tools required for assembly. Weight with water in the base 35kg Overall height 132cm

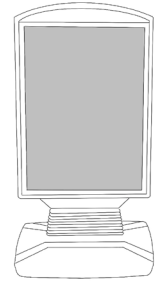

Size H 841mm
W 594mm
A1 **WP216**



To order any of the item that you saw in this booklet. Please head to our website to place an order or email us with all the information.

www.wonderwallproducts.co.uk sales@wonderwallproducts.co.uk

Wonderwall Products Ltd ®
Junction 39
Shap Industrial Park
Main Road
Shap
Cumbria CA10 3PW

